

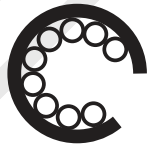

**Latch Lock Drawers**



**Ball Bearing Slides**



**Key Lock**

Edition : 1.0  
Date: (12/24)

# Instruction Manual

## PROFESSIONAL SERIES MOBILE WORK STATION DS-660

Order Code: (T6890)

### BEFORE ASSEMBLING

Please read this instruction manual before assembly.



#### CAUTION

Before assembly please pay attention to the following points in priority;

**Confirmation of components:** Before assembling, please confirm all parts arrived and are in good order.

**Site for assembly:** Please assemble it on the soft floor such as smooth carpet and flannel blanket. When you assemble on wooden floor, please put thin towels on the floor.

**Points for attention when assembling:** Please wear gloves to ensure that it can be assembled safely, and use two persons to help in the assembly process.

### SAFETY INFORMATION

1. Do not pull this workstation, push it when moving.
2. Engage both brakes when this workstation is not being moved. This prevents the workstation rolling away.
3. Secure this workstation properly before moving with a forklift.
4. Do not tow this workstation with power equipment.
5. Do not alter this workstation in any manner. For Example. Do not weld external lock bars or attach electrical equipment.
6. Before locking the workstation, ensure the drawers are completely closed in order for the lock bars to work properly.



**CAUTION:** Do not attach or mount this product to a vehicle. This may cause personal injury or product damage. Mounting this product to any vehicle in any manner will void warranty.



**CAUTION:** Keep the product on level surfaces. The product may become unstable and tip if stored or moved on an un-level surface, which may cause personal injury or product damage.



**CAUTION:** Do not stand on this product. You may fall which may cause personal injury or product damage.



**CAUTION:** Lock the drawers before moving this product. The drawers could come open and make the product unstable and tip, which may cause personal or product damage.



**CAUTION:** Be careful when opening more than one drawer. The product may become unstable and tip, which may cause personal injury or product damage.



# WORK STATION

## PROFESSIONAL SERIES



### SPECIFICATIONS

Overall size: 1141 x 730 x 725mm (WxDxH)  
Overall with casters: 1141 x 730 x 888mm (WxDxH)  
Package size: 1190 x 770 x 1036mm (WxDxH)

6 drawers: 570 x 410 x 83mm (30kg Per Drawer)  
2 drawers: 570 x 410 x 112mm (30kg Per Drawer)  
2 drawers: 570 x 410 x 228mm (50kg Per Drawer)  
Nett Weight: 173kg

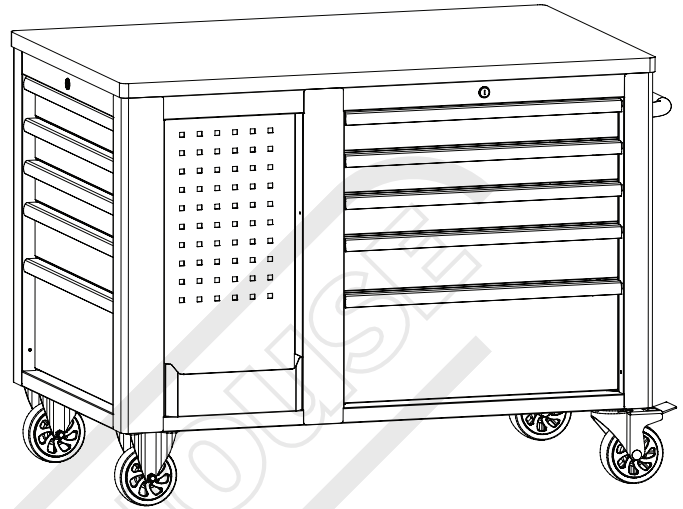

Fixed Wheels (x2)



Swivel Brake  
Wheels (x2)



Trolley Handle  
(x1)



Keys (x4)

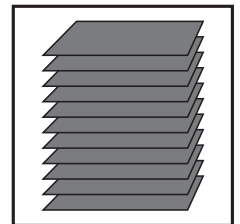

Drawer Liners  
(x10)



Shelves (x2)



Hanging Hooks  
(x8)



M10x20mm  
Bolts, Washers &  
Spring Washers  
(x16)



M6x16mm Bolts  
(x4)

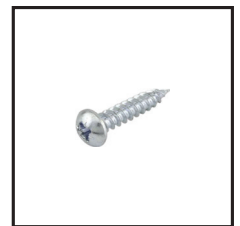

10G x 15mm  
Screws (x4)

### ASSEMBLY INSTRUCTIONS

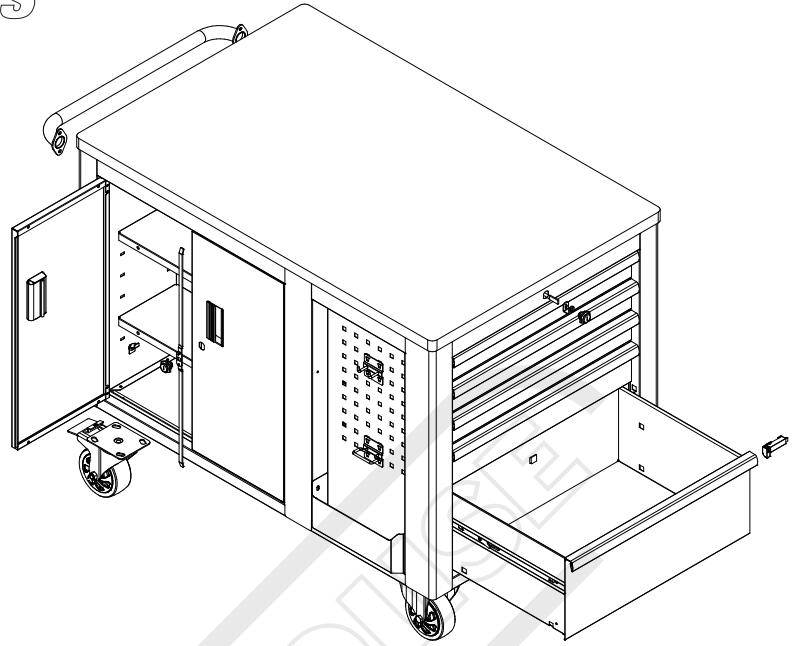

#### TOOLS & ASSISTANCE NEEDED

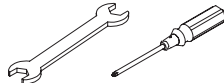

10,16mm spanners.  
Philips Head Screwdriver

\*Tools not included

### STEP 1.

#### Handle Installation

- Position the side handle in-line with the holes on the workstation.
- Attach with 4x M6x16mm bolts and tighten with a 10mm spanner/socket as shown in Fig. 1.

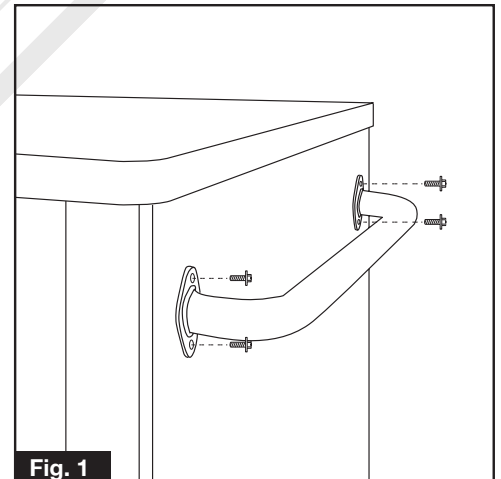

Fig. 1

### STEP 2.

#### Attaching the Wheels

- Be sure the drawers are locked and lay the cabinet on its top. Use packaging material or a blanket to protect the finish of the workstation.
- Attach the swivel brake wheels to the base of the workstation on the same side as the handle, using M10x20mm bolts, washers and spring washers as shown in Fig. 2. Tighten using a 16mm spanner/socket.
- Repeat this process for the fixed wheels on the opposite side of the workstation.
- Return the workstation to its upright position.

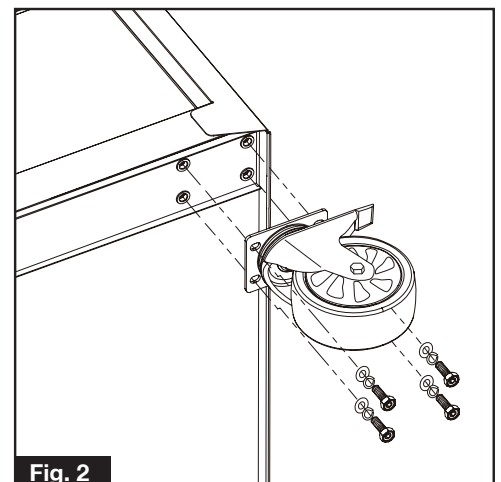

Fig. 2

# WORK STATION

## PROFESSIONAL SERIES



### ASSEMBLY INSTRUCTIONS

Cont...

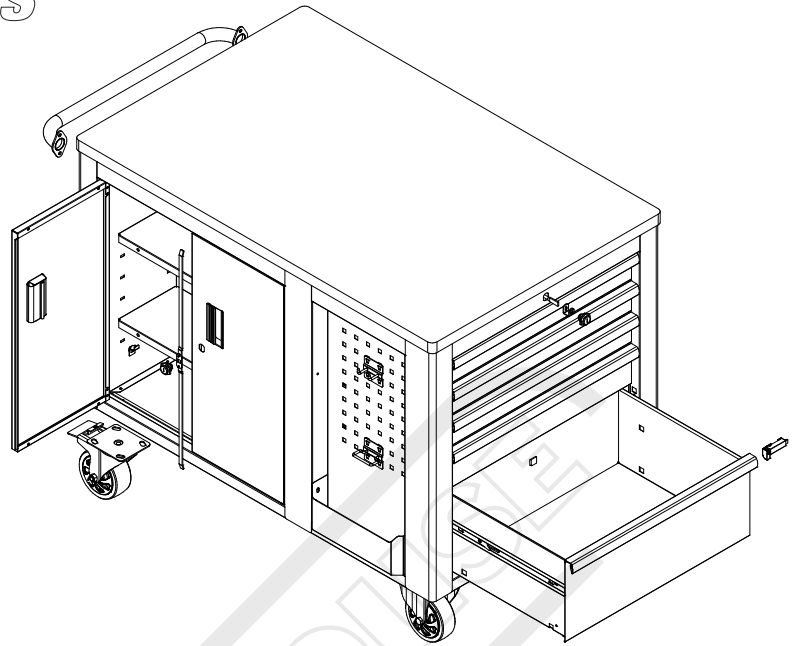

#### TOOLS & ASSISTANCE NEEDED

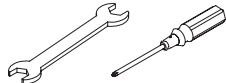

10,16mm spanners.  
Philips Head Screwdriver

\*Tools not included

### STEP 3.

#### Storage Holders Installation

- Position the storage holders in-line with the holes on the workstation.
- Attach with 2x 10Gx15mm screws per storage holder and tighten with a Philips head screwdriver as shown in Fig. 3.

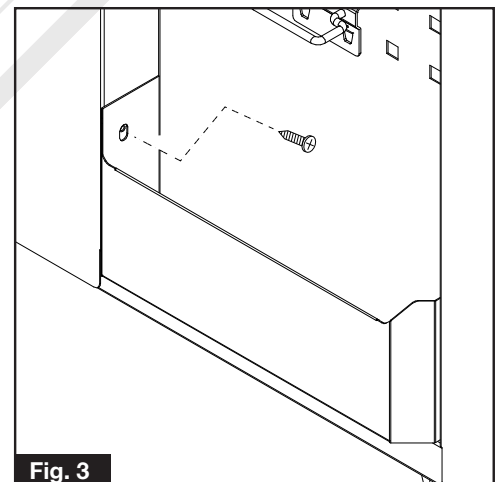

Fig. 3

### OPERATION

1.

#### Removing the drawers

- Release the drawer latch and fully extend the empty drawer.
- Push up one release lever while pulling down on the other release lever.
- Pull the drawer outward until it is released from the drawer slide and fully remove drawer from the slides.

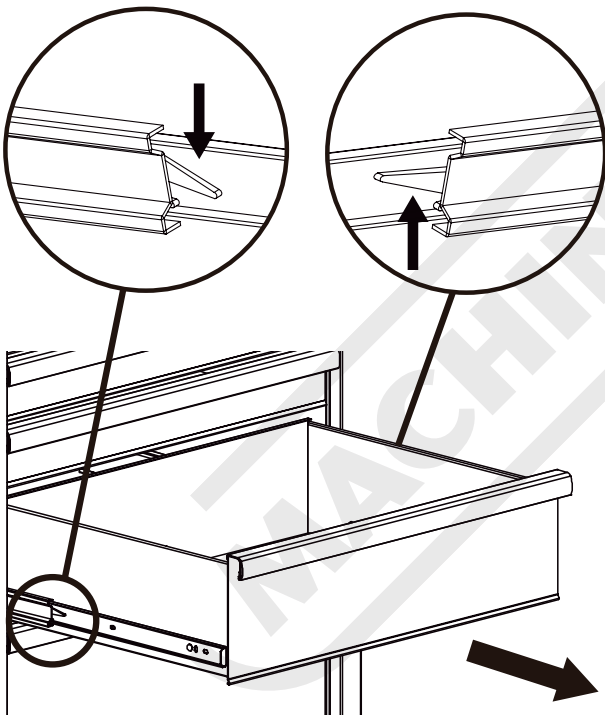

2.

#### Re-inserting the drawers

- Extend the drawer slides.
- Insert the brackets on each side of the drawer into the slots in the slides, being careful that they are properly positioned.
- Once properly inserted, completely close the drawer to set the slides in their proper positions and make sure you go all the way in to engage the drawer latch.

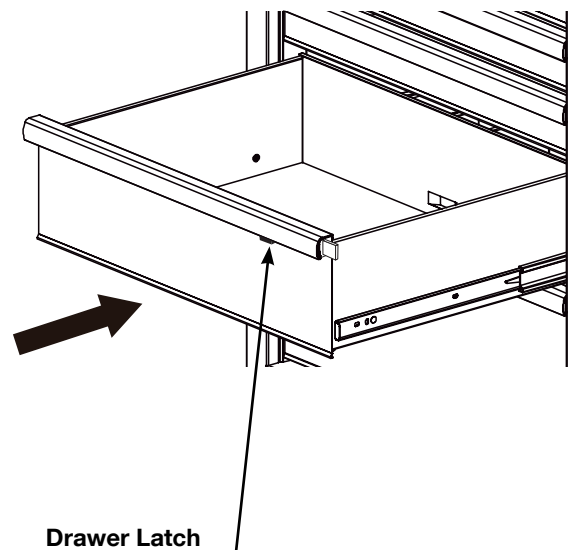

### MAINTENANCE

1. Wheel maintenance: Grease the wheels annually using high-quality bearing grease.
2. Drawer maintenance: Lubricate the slides semi-annually with high-quality bearing grease.





#### **ENVIRONMENT PROTECTION**

Recycle unwanted materials instead of disposing of them as waste. All tools, accessories and packaging should be sorted, taken to a recycling centre and disposed of in a manner which is compatible with the environment. When the product becomes completely unserviceable and requires disposal, drain any fluids (if applicable) into approved containers and dispose of the product and fluids according to local regulations.

Imported by

**HARE & FORBES**  
**MACHINERYHOUSE**

**Australian Distributor**

Hare & Forbes  
Machineryhouse  
Sydney - Melbourne  
Adelaide - Brisbane - Perth

Ph: 1300 202 200  
[www.machineryhouse.com.au](http://www.machineryhouse.com.au)

**MACHINERYHOUSE**

**New Zealand Distributor**

Machineryhouse  
Auckland  
Christchurch

Ph: 0800 142 326  
[www.machineryhouse.co.nz](http://www.machineryhouse.co.nz)